

# Speech Transfer Systems STS-K015, STS-K062, STS-K058

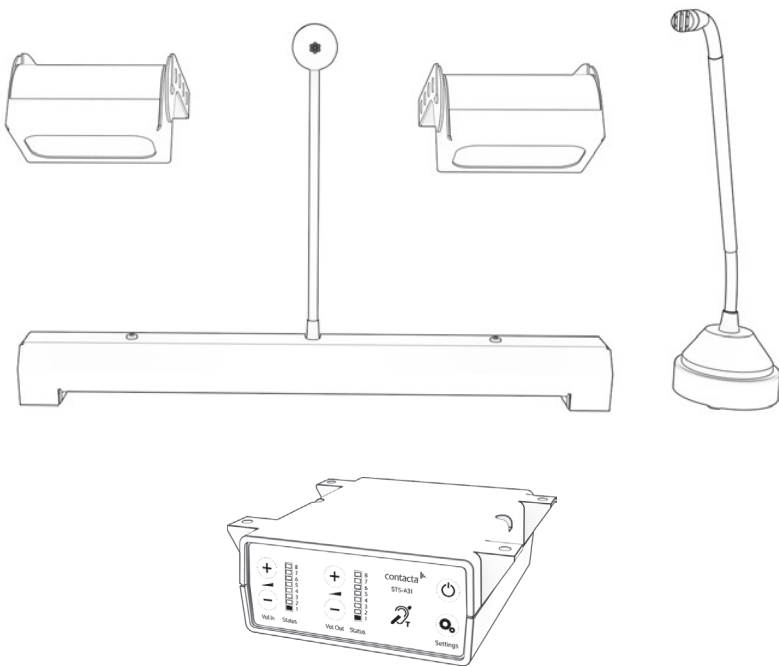

## Installation & User Guide

# Important Safety Instructions

1. Read these instructions.
2. Keep these instructions.
3. Heed all warnings.
4. Follow all instructions.
5. Do not use this apparatus near water.
6. Clean only with dry cloth.
7. Do not block any ventilation openings. Install in accordance with the manufacturer's instructions.
8. Do not install near any heat sources such as radiators, heat registers, stoves, or other apparatus (including amplifiers) that produce heat.
9. Do not defeat the safety purpose of the polarized or grounding-type plug. A polarized plug has two blades with one wider than the other. A grounding type plug has two blades and a third grounding prong. The wide blade or the third prong are provided for your safety. If the provided plug does not fit into your outlet, consult an electrician for replacement of the obsolete outlet.
10. Protect the power cord from being walked on or pinched particularly at plugs, convenience receptacles, and the point where they exit from the apparatus.
11. Only use attachments/accessories specified by the manufacturer.
12. Use only with the cart, stand, tripod, bracket, or table specified by the manufacturer, or sold with the apparatus. When a cart is used, use caution when moving the cart/apparatus combination to avoid injury from tip-over.
13. Unplug the apparatus during lightning storms or when unused for long periods of time.
14. Refer to all qualified service personnel. Servicing is required when the apparatus has been damaged in any way, such as power-supply cord or plug is damaged, liquid has been spilled or objects have fallen into the apparatus, the apparatus has been exposed to rain or moisture, does not operate normally, or has been dropped.

# Safety Precautions



Thank you for purchasing this system. Before using, please read the following guide to ensure correct usage. After reading, store this guide in a safe place for future reference. Incorrect handling of this product could possibly result in personal injury or physical damage. The manufacturer assumes no responsibility for any damage caused by mishandling that is beyond normal usage defined in this manual.

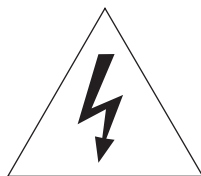

**This symbol is used to alert you to important instructions within this manual.**



**This symbol is used to alert you to the dangers of getting an electric shock.**

-  Ensure that you only use the supplied power supply. Do not attempt to install your own power supply system otherwise damage may occur.
-  Do not attempt to dismantle or modify any parts of the unit. No user serviceable fuses or parts are included.
- Ensure the system is not installed in areas of high ambient temperatures or high levels of humidity or dust.
- It should not be exposed to direct sunlight or be placed next to vibrating or heat generating equipment.
- This system is designed for indoor use only.
- Do not place the unit on an unstable surface.
-  Do not insert liquids or foreign objects. This could result in fire or electrical shock. If liquids or foreign objects should enter, immediately turn off the power switch, disconnect the power plug from the power outlet and contact your local dealer.
- Ensure the aerial is taped down securely. Do not leave any trailing leads that may cause a trip hazard.

If a problem occurs with the equipment, first refer to the Troubleshooting section of this guide, and run through the suggested checks. If this does not resolve the problem contact your dealer. They will tell you what warranty condition is applied.

# Contents

Product Overview	5
Components	5
Tools Required	6
Installation Instructions STS-K015	7
Installation Instructions STS-K062	10
Installation Instructions STS-K058	15
Connections	16
Amplifier Setup	17
Using the System	19
Troubleshooting	21

# Product Overview

Speech transfer systems provide assistance for clear communication where normal speech is impaired by use of glass, a security screen or other similar barriers.

There is also a hearing loop facility included which provides additional assistance for hearing device wearers.

## Components

1. Installation and User Manual
2. A31H Amplifier
3. Overhead Speakers (for models K015 and K062), or a Surface Mount speaker for model K058.
4. Bent Vandal-Proof Microphone (for model K058) or a straight stem Microphone for models K015 and K062
5. Staff Mic Unit (for models K015 and K062) or a Staff Loudspeaker unit for model K058
6. Hearing Loop Sticker
7. IEC Lead
8. Hearing Loop Aerial
9. Power Supply
10. Mounting Bracket

Also included is a Fixing Kit, which contains:

1. Adhesive Clip x10
2. No.6 x 1/2" Countersunk Screws x15
3. P-Clips x6

# Tools Required

## Your basic toolkit will include:

- Screwdrivers (Flat or Blade 2.5mm and Phillips Head PH2)
- Battery or Mains Drill
- Drillbits: 2mm, 3mm, 5mm and 7mm
- Allen Key Set
- Cable Tacking Gun (10mm)
- Wire Cutters/Strippers
- Pliers
- Tape Measure
- Pencil or Marker Pen
- Torch
- Cable Ties
- Electrical Insulation Tape
- Trunking

# Installation Instructions STS-K015

Install the Staff Microphone, Amplifier, Overhead Loudspeakers, Bridge Bar Unit and Surface Mic in the order described below. If you have followed the steps closely and the system is not functioning as intended, consult Troubleshooting on page 21.

## Staff Microphone, Amplifier and Overhead Loudspeakers



1. Place the staff microphone on the staff side of the counter top, ensuring that it does not cause an obstruction and is as close to staff as possible.
2. Place the amplifier under the staff counter, ensuring that it will not obstruct staff when they are sitting.
3. Mark the 4 fixing points for the amplifier under the counter.
4. Drill and fix the amplifier in place using the supplied screws.
5. Use the cable management hole to run the staff microphone cable back to the amplifier. If there is not already a cable management hole, one will need to be drilled in a suitable location near the rear of the counter.

6. Install the overhead loudspeakers:

- a. Find a location on the staff side directly above the pass-through tray. Ensure there is sufficient space and there is no glass behind where you want to drill.
- b. Check the cable route to the amplifier situated under the counter. Ensure access through the counter top and suitable cable length. Drill a cable hole through the rear of the counter if necessary.
- c. Mark 2x fixing points to attach the overhead speakers.
- d. Drill pilot holes and attach the loudspeaker bracket assembly using supplied screws.
- e. Route the cable from the loudspeaker back to the amplifier in a neat and tidy fashion, using cable containment where required.
- f. Repeat the above steps on the customer side of the counter.

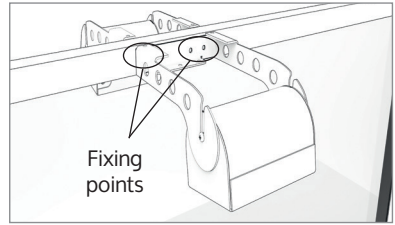

7. Install the power supply close to a power socket outlet using the supplied mounting bracket and fixing screws.

### Bridge Bar Unit and Surface Mic

1. Position the bridge bar unit on the customer side of the counter top in a central location or around the pass-through tray if present.
2. Ensure the microphone and bridge bar are flat against the screen.
3. Mark the 2 fixing points and 1 cable route hole ready for drilling.
4. Drill pilot holes and a cable hole and attach the assembly with the supplied screws.
5. Feed wiring through the cable hole back to the amplifier. Using provided fixing holes and screws, attach the bridge bar cover carefully to avoid damage to wiring.

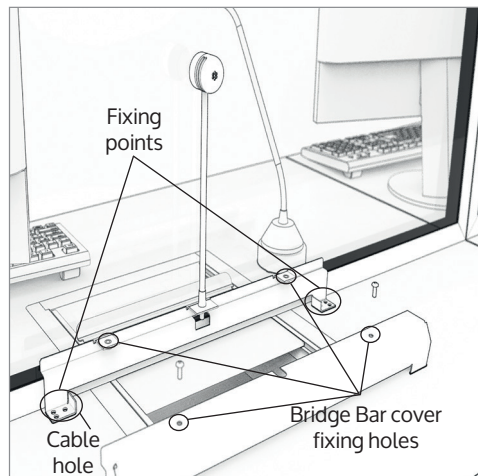



## Under-Counter Hearing Loop Aerial Installation

The aerial should be fixed under the desk-top or counter centrally on the customer side, one half mounted horizontally under the counter and the other half mounted vertically, facing the customer (as in the first scenario below).

Position the aerial under the counter using either the provided P-clips or another fixing method of your choice. See the diagram below for recommended positioning.

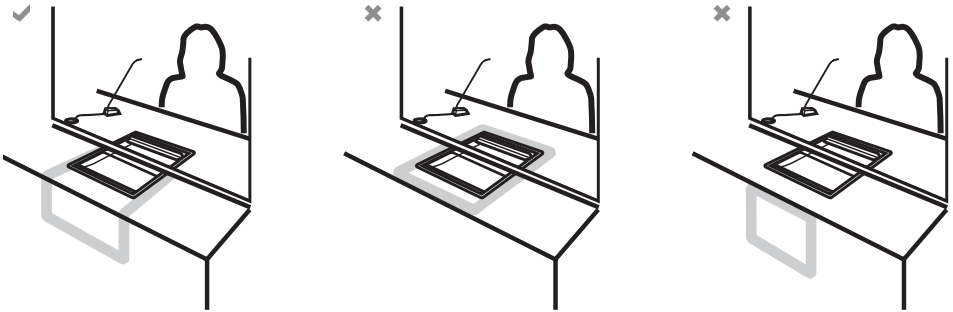

Ensure all hearing loop signage is displayed clearly.

# Installation Instructions STS-K062

## Staff Microphone, Amplifier and Overhead Loudspeaker

1. Place the staff microphone on the staff side of the counter/checkout, ensuring that it does not cause an obstruction and is as close to staff as possible.
2. Place the amplifier under the staff counter/checkout, ensuring that it will not obstruct staff when they are sitting.

3. Mark the 4 fixing points for the amplifier under the counter.
4. Drill and fix the amplifier in place using the supplied screws.
5. Use the cable management hole to run the staff microphone cable back to the amplifier. If there is not already a cable management hole, one will need to be drilled in a suitable location near the rear of the counter/checkout.

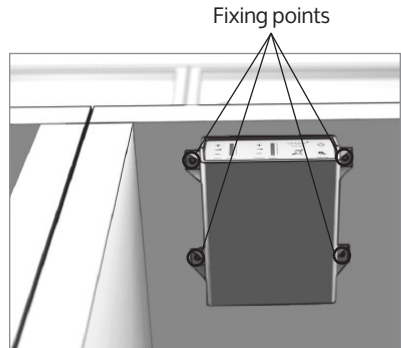

6. Install the overhead loudspeakers:
  - a. Find a location on the staff side directly above the pass-through tray. Ensure there is sufficient space and there is no glass behind where you want to drill.
  - b. Check the cable route to the amplifier situated under the counter/checkout. Ensure access through the counter/checkout and suitable cable length.
  - c. Mark 2x fixing points and 1x cable hole to attach the overhead speakers.

- d. Drill pilot holes and attach the loudspeaker bracket assembly using supplied screws.
- e. Route the cable from the loudspeaker back to the amplifier in a neat and tidy fashion, using cable containment where required.
- f. Repeat the above steps on the customer side of the counter.

**Note**

If you are fitting the overhead speakers back to back on a perspex screen you will need to drill through the perspex. The speaker can then be blotted together.

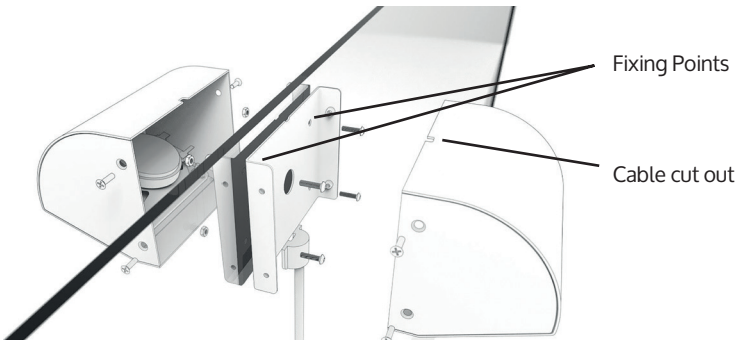

7. Install the power supply close to a power socket outlet using the supplied mounting bracket and fixing screws.

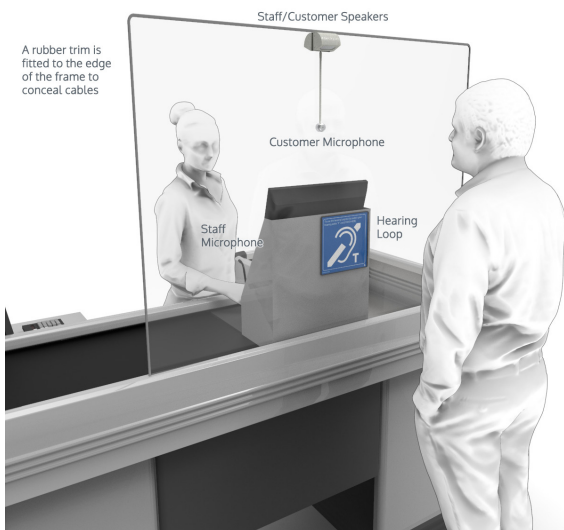

## Anti Vandal Microphone

1. Install the microphone to the screen, this should be installed centrally under the overhead speaker
2. Use the double side pads on the back of the microphone head and the back of D-shaped bracket at the base of the microphone stem.
3. Route the cable from the loudspeaker back to the amplifier in a neat and tidy fashion, using cable containment where required.



## Above-Counter Induction Loop Aerial Installation

The induction loop aerial should be installed in the best possible location as close to where the customer will be standing as possible.

1. The aerial can be fitted onto the counter/checkout using the double-sided pad supplied or cable ties.
2. Route the cable from the induction loop aerial back to the amplifier in a neat and tidy fashion, using cable containment where required.



# Installation Instructions STS-K058

Install the Staff Loudspeaker unit, Amplifier and Bent Vandal-Proof Microphone in the order described below. If you have followed the steps closely and the system is not functioning as intended, consult Troubleshooting on page 21.

## Staff Loud Speaker Unit and Amplifier

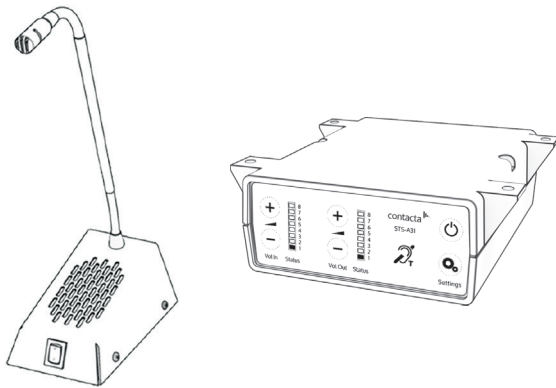

1. Place the Staff Loudspeaker Unit on the staff side of the counter top, ensuring that it does not cause an obstruction and is as close to staff as possible.
2. Place the amplifier under the staff counter, ensuring that it will not obstruct staff when they are sitting.
3. Mark the 4 fixing points for the amplifier under the counter.
4. Drill and fix the amplifier in place using the supplied screws.
5. Use the cable management hole to run the Staff Loudspeaker Unit cable back to the amplifier. If there is not already a cable management hole, one will need to be drilled in a suitable location near the rear of the counter.

## 6. Install the Surface Mounted Speaker:

- Place the speaker pods on the customer side of the counter top.
- Disassemble the speaker pods by undoing the screws and removing the housing.
- Place the mounting brackets next to the pass-through tray/opening, at least 2-3mm away from the screen.
- Mark the two fixing points and the cable holes to be drilled.
- Ensure there will be access to retrieve the cables and drill the holes.
- Fix the speaker pods to the counter, and feed the wires through the cable management holes.
- Refit the housing with previously removed screws.
- Route all cabling neatly to the amplifier location on the staff side.

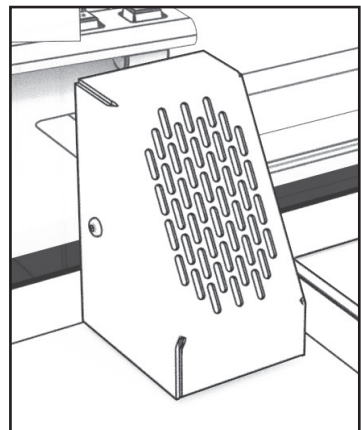
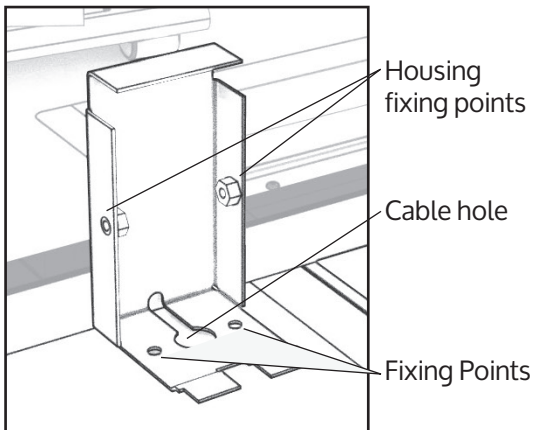

## Anti Vandal Microphone

1. Position the microphone stem on the customer side of the counter top.
2. Mark the 2 fixing points and 1 cable route ready for drilling.
3. Drill pilot holes for the fixings and a cable hole.
4. Feed wiring through the cable hole back to the amplifier and fix the microphone in place using the supplied screws.
5. Fix the microphone head to the screen using the double-sided pad supplied.

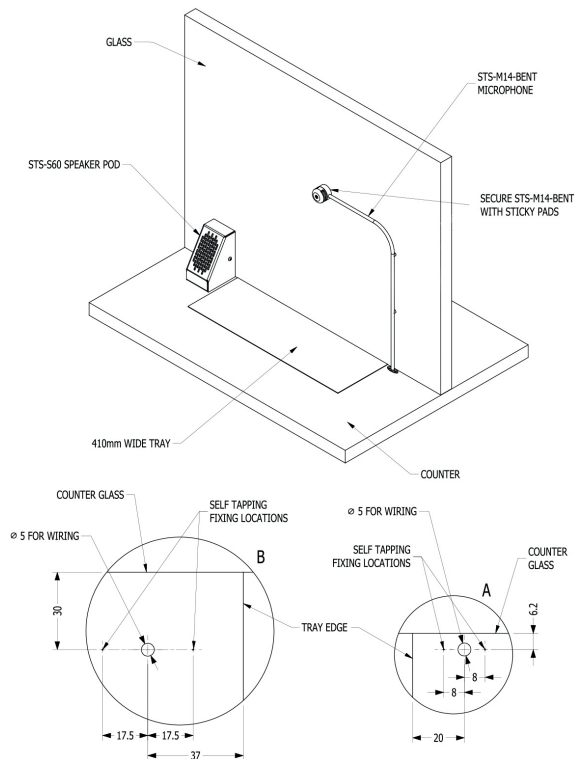
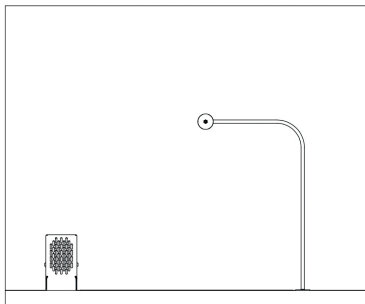
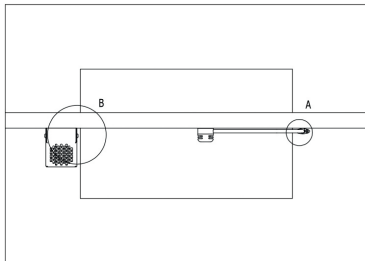

# Connections

Trim the cables if necessary (apart from the power supply) to the required length for connection to the back of the amplifier. Bare approximately 6mm of the cable ends for connection to the 2 pin plugs (see diagram below).

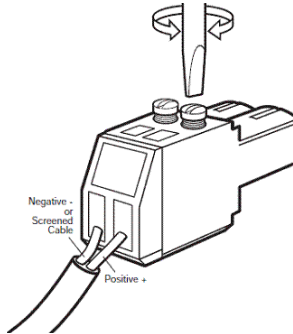

## Rear Amplifier Connections

Connect all green plugs to the back of the amplifier, observing the correct locations printed about the sockets (see below diagram).

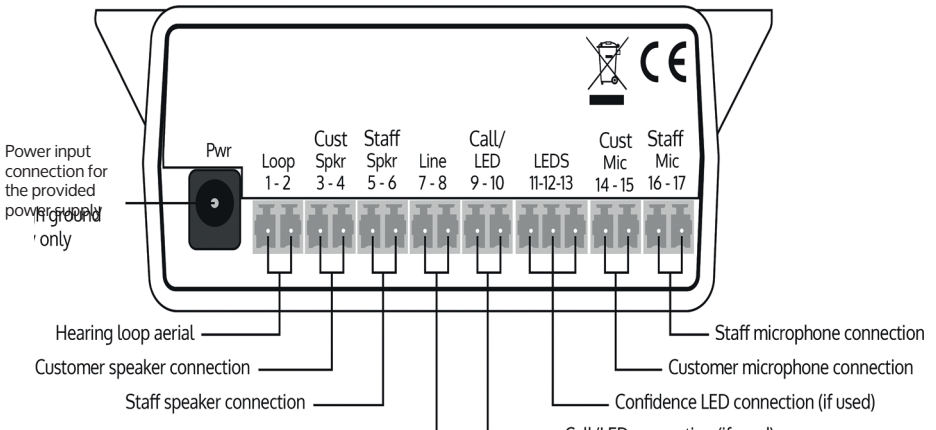



# Amplifier Setup

Our amplifier provides full open duplex communication and is compatible with all of our speech transfer systems. It features individual displays for staff or customer adjustments and individual fault lights for easy fault diagnosis.

## Overview of Front Panel Buttons

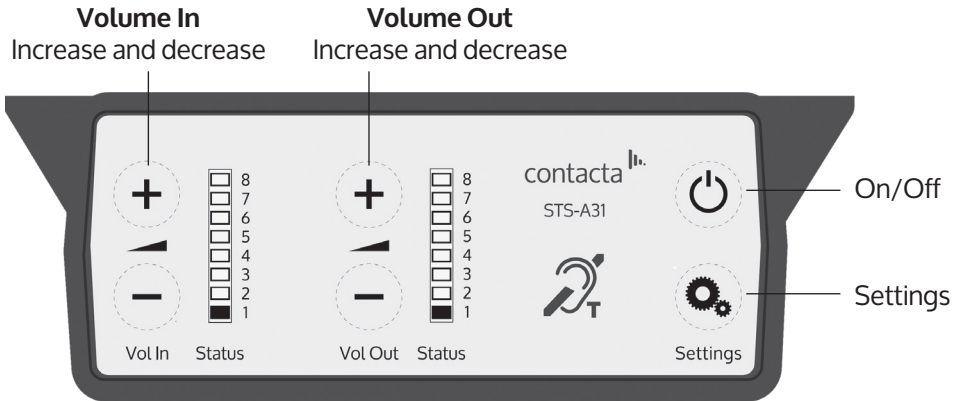

## Engineers Mode

Before entering engineers mode, cycle the power. To do this either:

- Switch the power off at the wall socket and back on again.  
or
- Remove the power connector and re-insert it.

To enter engineers mode, simultaneously press and release the following buttons within 20 seconds of cycling the power:

- Settings button
- Volume In increase button
- Volume Out increase button

The on/off and settings buttons in engineers mode operate as follows:



Move to the next setup area



Save and exit engineers mode

Please note

- Save and exit engineers mode after making any adjustments.
- The amplifier will automatically exit engineers mode without saving if no buttons are pressed for 2 minutes.

## Setup Areas

Whilst in engineers mode, there are 3 editable setup areas. You will always enter setup area 1 first. The green Volume In LED bar will flash to indicate which setup area you are in.

### Setup Area 1:

#### Maximum Volume Adjustment (LED 1 flashes)

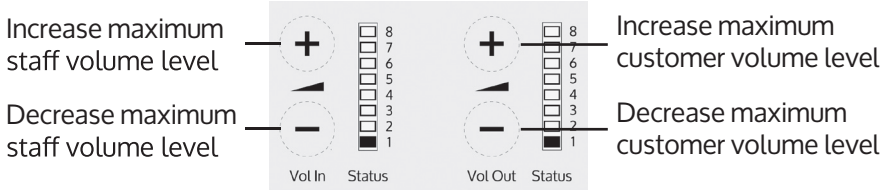

### Setup Area 2:

#### Ducking Adjustment (LED 2 flashes)

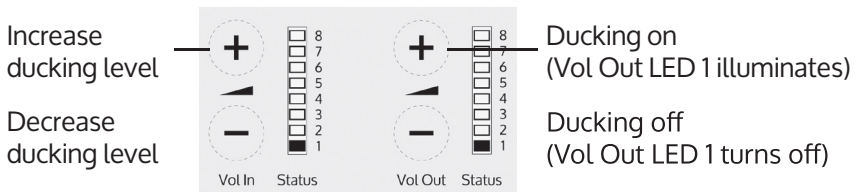

### Setup Area 3:

#### Hearing Loop Drive Adjustment (LED 3 flashes)

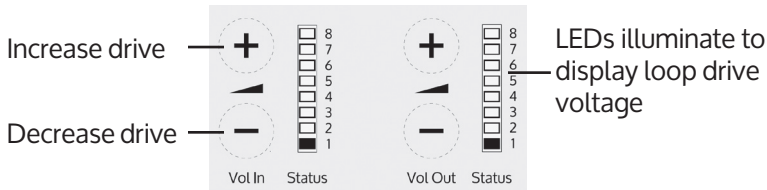

The drive level should be adjusted so the red LED 8 is illuminated only when there are peaks in the speech volume.

If the amplifier does not have a loop attached, you can turn off the red loop fault LED 8 by adjusting the drive down to off.

#### Please note:

- If the amplifier detects an error in its' settings memory it will restore itself to factory default settings.

# Using the System

When powered and in normal operational mode the amplifier will display Volume In LED 1 as steady green.

When the amplifier is switched off using the On/Off button, audio is muted and LEDs are not illuminated; press any button to turn the amplifier on again.

To adjust the **staff volume** level:

Press and hold the Volume In (+) or (-) buttons to increase or decrease the level. The corresponding LED bar will show the volume setting.

To adjust the **customer volume** level:

Press and hold the Volume Out (+) or (-) buttons to increase or decrease the level. The corresponding LED bar will show the volume setting.

## For best possible performance:

1. Ensure the customer and staff volumes are turned completely down.
2. Adjust staff volume (Volume In) to a comfortable level.
3. Increase customer volume (Volume Out) until feedback is heard.
4. Decrease customer volume (Volume Out) until feedback is just eliminated.

Once you have followed the above steps:

1. The staff microphone is best positioned no more than 300mm away from the staff member.
2. Check the amplifier is fully functional by ensuring the red 'fault' light is NOT displaying.

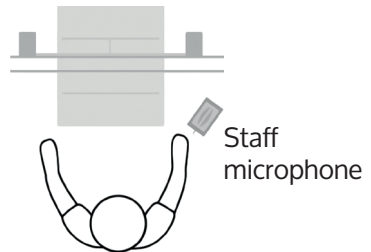

If there is insufficient volume even after you have adjusted the volume controls, enter engineers mode and raise max volume settings. Exit engineers mode and repeat initial setup.

The system is now ready to use.

## Fault Diagnosis LEDs

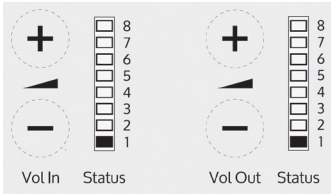

- Volume In LED 8 will stay red if there is a fault with the staff microphone.
- Volume Out LED 8 will stay red if there is a fault with the customer microphone.
- Volume In LED 8 will flash red if there is a fault with the loop (i.e. a broken aerial).

## Factory Default Settings

To return the amplifier the factory default settings:

1. Unplug the power supply and then reconnect it.
2. Press the On/Off button and Volume In (-) button together, then release.
3. The Volume In LED bar will have all LEDs illuminated, while the Volume Out LED bar will display the firmware revision number in a fixed pattern of LEDs. This indicates that default settings have been restored.

# Troubleshooting

Symptom	Possible Fault	Action
<b>There is no power detected through amplifier (and there is power at the socket).</b>	<ol style="list-style-type: none"> <li>1) Power jack not plugged in or faulty.</li> <li>2) Plug fuse has blown.</li> <li>3) Faulty power supply unit.</li> <li>4) Faulty amplifier.</li> </ol>	<ol style="list-style-type: none"> <li>1) Check power jack is firmly plugged in.</li> <li>2) Replace fuse, but if it blows again contact your supplier.</li> <li>3) Replace the power supply unit.</li> <li>4) Replace amplifier.</li> </ol>
<b>The red LED is illuminated on front panel.</b>	<ol style="list-style-type: none"> <li>1) <b>Constant red LED:</b> Staff or customer microphone fault.</li> <li>2) <b>Red LED comes on after speech:</b> Induction loop fault.</li> </ol>	<ol style="list-style-type: none"> <li>1) Ensure microphone is wired correctly and firmly plugged in. Try alternative microphone to ensure port is working.</li> <li>2) Ensure induction loop connector is wired correctly and firmly plugged in.</li> </ol>
<b>I can't hear audio through the induction loop.</b>	<ol style="list-style-type: none"> <li>1) Induction loop or microphone is disconnected.</li> <li>2) Faulty loop tester.</li> </ol>	<ol style="list-style-type: none"> <li>1) Check instructions for correct connections and, if possible, check the hearing device with a known working hearing loop.</li> <li>2) Ensure loop tester has a new set of batteries.</li> </ol>
<b>I can hear interference through speakers (buzzing / whistling / hissing).</b>	<ol style="list-style-type: none"> <li>1) Unscreened or poorly earthed third party equipment is being used in close proximity.</li> <li>2) Internal volume gain set to high.</li> <li>3) Incorrect power supply being used.</li> </ol>	<ol style="list-style-type: none"> <li>1) Switch off any third party equipment to identify the source of interference.</li> <li>2) Access the amplifier Engineer Mode to adjust the internal settings.</li> <li>3) Ensure that our grounded power supply unit is connected.</li> </ol>
<b>Amplifier goes into feedback.</b>	<ol style="list-style-type: none"> <li>1) Internal volume gain set to high.</li> <li>2) Microphone positioned too close to speaker.</li> </ol>	<ol style="list-style-type: none"> <li>1) Access the amplifier Engineer Mode to adjust the internal settings.</li> <li>2) Move the microphone to a location further from the speaker.</li> </ol>
<b>Unit does not go into power saving mode.</b>	<ol style="list-style-type: none"> <li>1) Ambient noise in area is too high.</li> </ol>	<ol style="list-style-type: none"> <li>1) Switch off any air con systems, desktop fans and or computers to reduce ambient noise.</li> </ol>

If no action is successful please seek assistance from your distributor or a Contacta installer.

contacta 

Contact your local  
distributor for further  
information.

Contacta, Inc.  
(616) 392-3400  
[support@contactainc.com](mailto:support@contactainc.com)

[www.contactainc.com](http://www.contactainc.com)